

FloScan 201 Flow Transducer

Series 200 Flow Transducer Application Notes

1. The inlet and outlet ports in series 200 flow transducers have 1/4" NPT threads. Use only 1/4" NPT hose or pipe fittings to match. When assembling fittings into the inlet and outlet ports DO NOT EXCEED a torque of 15 ft. lbs. (180 inch lbs.), or screw the fittings in more than 2 full turns past hand tight, WHICHEVER COMES FIRST. FloScan Instrument Co., Inc. will not be responsible for cracked castings caused by failure to use 1/4" NPT fittings, over torquing the fittings, or assembling them beyond the specified depth.
2. A screen or filter should be installed upstream of the flow transducer to screen out debris which could affect rotor movement or settle in the V-bearings. As turbulence upstream of the transducer affects its performance, there should be a reasonable length of straight line between the transducer inlet and the first valve, elbow, or other turbulence-producing device.
3. Install the flow transducer with wire leads pointed UP to vent bubbles and insure that rotor is totally immersed in liquid. For maximum accuracy at low flow rates the transducer should be mounted on a horizontal surface.
4. Power supply: 12 VDC at 100mA filtered and regulated.
5. Series 200 flow transducers are designed to measure steady state flows. Indicated accuracies and pulse counts were obtained using heptane on a flow stand with rotary pumps and are reproducible in flow systems using rotary or gear pumps. Fuel systems with diaphragm fuel pumps and carburetors produce pulsating fuel flows. For accurate results on these systems consult the factory for the correct flow transducer/pulsation damper combination.

Wiring the FloScan Flow Transducer

The RDAC unit measures the output from the transducer. A 5600 ohm (5k6) pull-up resistor is required (and provided). See wiring table and diagrams below.

Once the sensor is connected to the RDAC, refer to the Stratomaster instrument's (Enigma, Odyssey, Voyager, other) user manual for information regarding the setup of the transducer (for example the K factor).

The gallon per hour K factor for the 201A-6 transducer is approximately 32,000. The K-Factor of each sensor (at 16 GPH), divided by 10, is written on a label attached to sensor. Multiply this number on the label by 10, which should give a value of approximately 32,000. The Stratomaster requires a litre per hour K factor. Take the gallon per hour K factor, and divide it by 3.785 (which yields a K factor of approximately 8454, to be used by the Stratomaster).

Transducer Wire Colour	RDAC Terminal Label / Other connector
White	FF Data / Signal / Injector
Black	FF Neg / Ground or Aircraft Ground / Engine block
Red	+12 V DC supply (not supplied by RDAC)

Notes:

1. The FF GND and REF GND terminals of the RDAC V are internally joined. At least one of these RDAC terminals need to be connected to the aircraft engine block / aircraft ground. Therefore, the flow sender can be connected to either the RDAC or the engine block.
2. During laboratory tests, the FloScan sender was successfully powered using the FF +5V output terminal of the RDAC. If the aircraft 12V supply is very noisy, it might be worth considering powering the transducer from this RDAC supply terminal (or clean up the 12V!).

RDAC X Wiring:

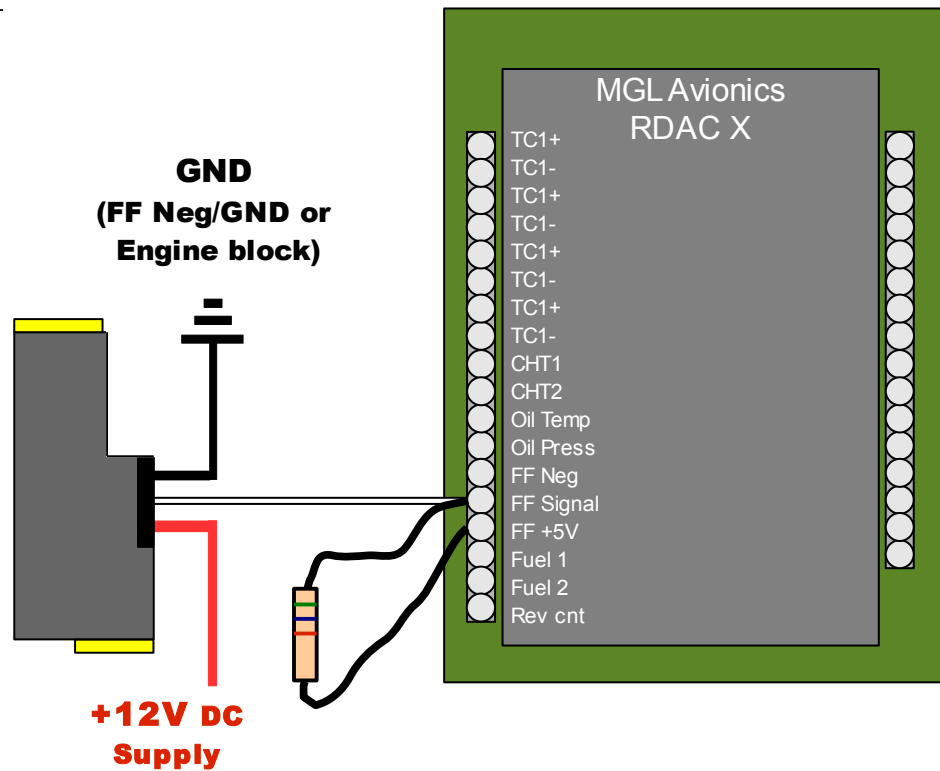

RDAC V wiring:

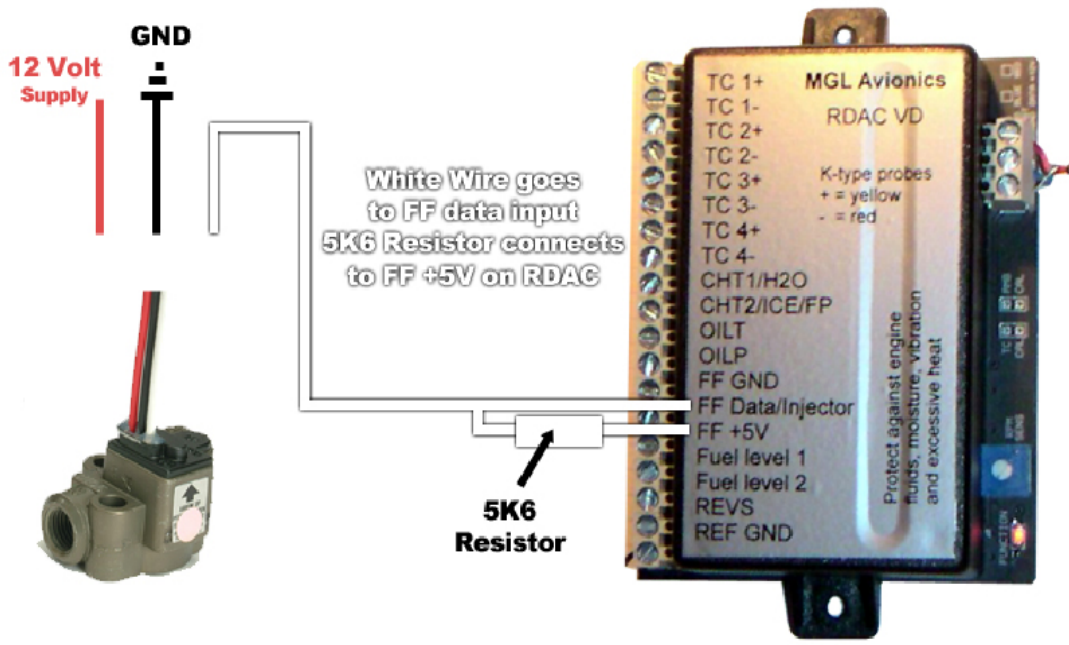

FloScan Flow Transducers - Series 200

Description

Series 200 Turbine Flow Transducers measure flows of hydrocarbon fuels such as gasoline, kerosene, and #2 diesel fuel and other light transmitting, non-corrosive liquids of similar viscosity. Typical fuel flow applications include aircraft fuel monitoring systems; gasoline, diesel, and gas turbine engine test stands; and industrial furnaces. The transducers give repeatable signals on gasoline across a 100 to 1 flow range down to 0.3 GPH. The higher viscosity of diesel fuel reduces signal repeatability at flow rates below 2 GPH. Pressure drops are very low compared to other turbine flow transducers. The transducer bearing system is rated for continuous operation at the upper end of the flow range. The transducers produce a current pulse signal from an opto-electronic pickup with a preamplifier.

Principal of Operation

Liquid enters the flow chamber tangentially, follows a helical flow path, and exits vertically, thereby venting any entrained vapor bubbles. The rotational velocity of the liquid is directly proportional to flow rate. A neutrally buoyant rotor spins with the liquid between V-jewel bearings. Rotor movement is sensed when notches in the rotor interrupt an infrared light beam between an LED and phototransistor. The vapor venting design requires that the transducer be positioned with the electrical connectors pointing up. Turbulence caused by valves or sharp elbows mounted close to the transducer inlet can affect transducer K-Factor and should be minimized.

Performance Specifications

Model Number	201A-6	201B-6	201C-6
Flow range: Gasoline	0.3 – 30 GPH	0.6 – 60 GPH	2.0 – 80 GPH
Flow range: #2 Diesel	2.0 – 30 GPH	3.0 – 60 GPH	8.0 – 80 GPH
Approximate K Factor ¹ : Gasoline	32,000	28,000 – 31,000	24,000
Approximate K Factor ¹ : #2 Diesel	33,000	28,000	25,000
Pressure Drop: Gasoline	0.6psi @ 15GPH 2.4psi @ 30GPH	1.2psi @ 30GPH 4.8psi @ 60GPH	1.4psi @ 40GPH 5.8psi @ 80GPH
Pressure Drop: #2 Diesel	0.8psi @ 15GPH 3.0psi @ 30GPH	1.5psi @ 30GPH 6.0psi @ 60GPH	1.8psi @ 40GPH 7.2psi @ 80GPH
Repeatability between Measurements	0.25% @ 16GPH	0.25% @ 16GPH	0.25% @ 16GPH
Working Pressure	200psi	200psi	200psi
Temperature Range	-65°/ 100°C	-65°/ 100°C	-65°/ 100°C
Bearing Life Expectancy	10,000 hr.min.	10,000 hr.min.	10,000 hr.min.

Notes:

1. Pulses/Gallon @ 16 GPH
2. All flow transducers are tested and marked with K-factor at 16 GPH. Repeatability at 16 GPH is guaranteed to 0.25%. Transducers are available with calibrated K-factors at additional cost.

Material Specifications

Flow Transducer Body	Die-cast Aluminum, Cadmium Plated, Dichromate Finish
Rotor	Nylon 6/12
Rotor Pivot	Stainless Steel, Carpenter 420
Phototransistor	SD 1440
Light Emitting Diode	SE 1450
Connectors	22 Gauge Wire Leads (3)

Electrical Specifications

12 to 15 VDC between RED (+) wire and BLACK (-) wire. 30 to 50 mA at 12 VDC.

Signal Specifications

Open collector transistor output on WHITE wire. Sensor will pull-down to 1.0 volt with 10-15k ohm pullup resistor installed.

Dimensions (inches)

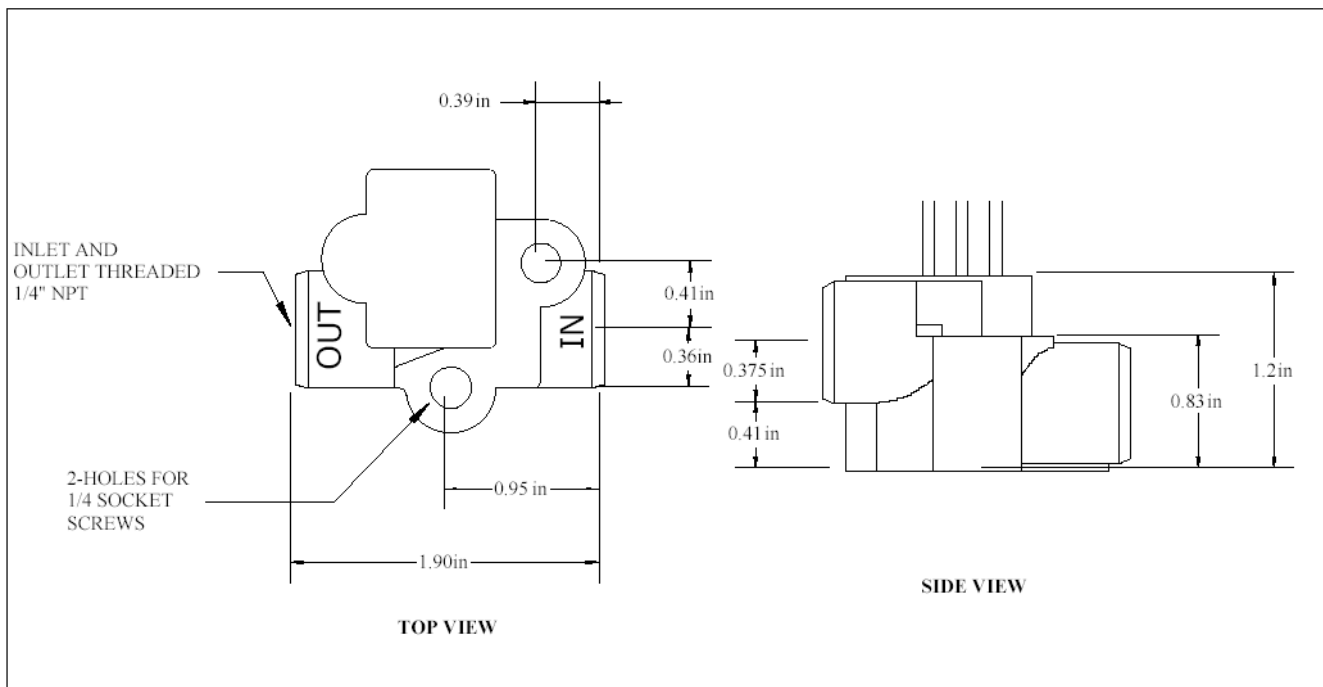

For more information on the FloScan transducer, visit <http://www.floscan.com/html/blue/aviation.php>.